

Model SR-202 from Slide-Rite®

The Right Solution for Superior Slider Retention for Large and Small Packages

Applies sliders and end clips in one step.

Application Specifics



Slider Types

- Standard (general use)
- "S"-slider (superior top retention)
- Particle Plow (cleans track before closing)

End Retention Types

- End Clips (superior slider retention)

Track Types

- Standard Two-Piece
- Tamper-Evident
- EOT (Easy-Open Track)



Total Zipper Technology

SR-202: A Detailed Look

Model SR-202

- 1 Track Unwind
- 2 Track Seal
- 3 Track Preseal
- 4 Slider and End Clip Application
- 5 ETM
- 6 Finished Packages with Slide-Rite®

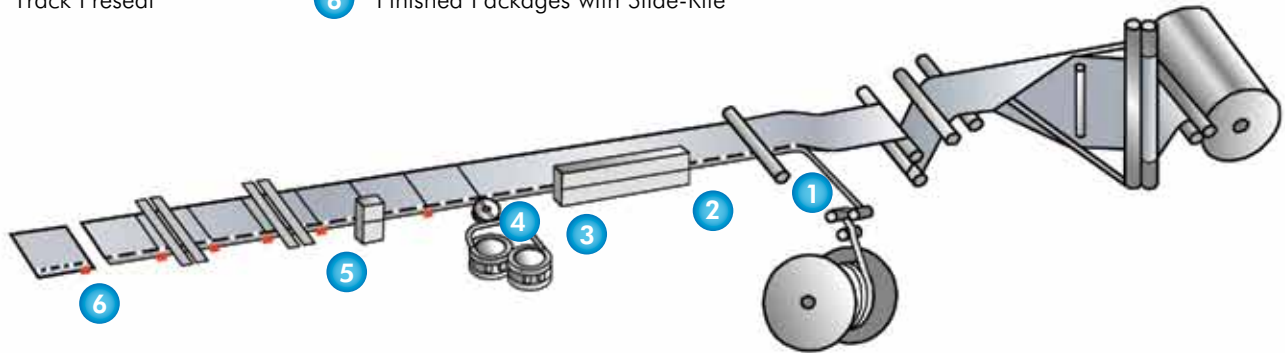

Machine Specifications	
Production Speed	100 cycles per minute
Package Widths (in.)	Standard 6 to 20 inches (152 to 508 mm) Above 20 inches available on request
Electrical Requirements	200-240 VAC, 3 phase, 50-60 Hz, 30 Amps
Compressed Air Requirements	5 SCFM, 50 psi, (141 liters/min., 0.34 MPa)
Shipping Weight (approx.)	6,500 lbs. (2950 Kg)

Machine Features

- Adjusts to film print registration for accurate end clip placement
- Stand-alone design includes electrical panel and operator interface on a single machine frame
- Optional wide clip available
- Optional track preseal and ETM modules may be added to SR-202 frame
- Allen-Bradley controls are standard, Ormec and others available optionally

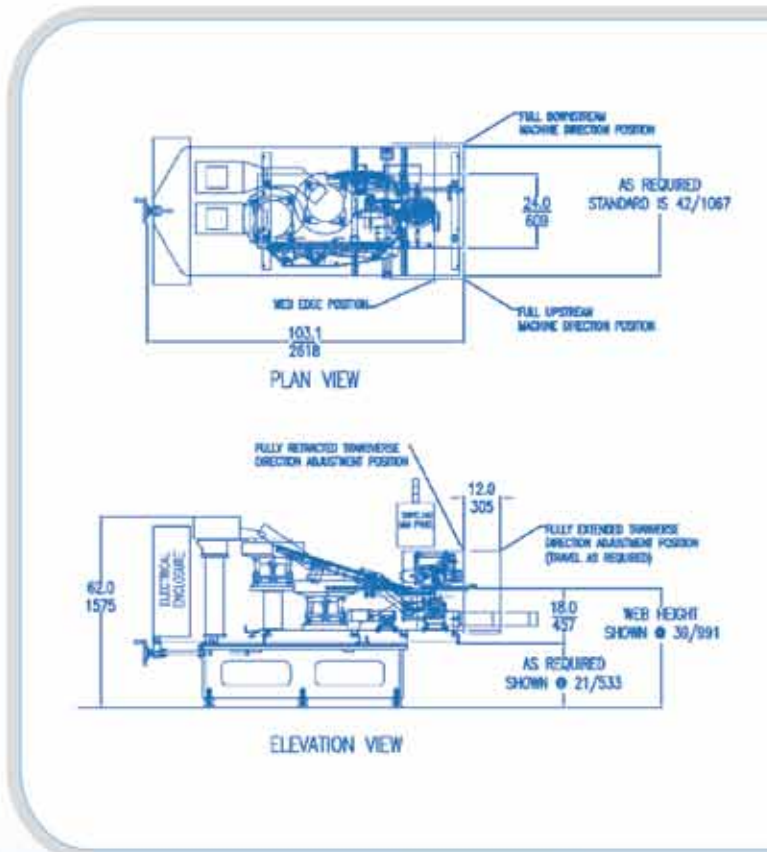

Presto Products Company • A Business of Reynolds Packaging Group • P.O. Box 2399 • Appleton, WI 54912-2399
(800) 265-0750 • Fax: (920) 738-1347 • E-mail: fresh-lock@reynoldspkg.com

www.fresh-lock.com